

THE GEOCHEMICAL NEWS

Newsletter of The Geochemical Society

NUMBER 107

ISSN 0016-7010

APRIL 2001



The European Synchrotron Radiation Facility



John H. Reynolds (1923-2000)

Eleventh Annual V. M. Goldschmidt Conference

**May 20-24, 2001
The Homestead
Hot Springs, Virginia, USA**

Additional information is on the Conference Web site:

<http://www.lpi.usra.edu/meetings/gold2001/>

In this issue:

From President Mike Hochella.....	3
Open Letter From Francis Albarede.....	4
Touret Receives Honorary Doctorate.....	5
From the GS Business Office.....	6
Fungi, Bacteria, and Geochemistry.....	8
In Memoriam: John H. Reynolds.....	10
In Memoriam: Samuel S. Goldich.....	12
European Research Facilities, II: ESRF.....	14
Meetings Calendar.....	19
GS Special Publications.....	22
GS Membership Application Form.....	23



OFFICERS - 2001

PRESIDENT

Michael F. Hochella, Jr., Virginia Polytechnic Institute

VICE PRESIDENT

Judith McKenzie, ETH, Zurich

PAST PRESIDENT

Michael J. Drake, University of Arizona

SECRETARY

David J. Wesolowski, Oak Ridge National Laboratory

INTERNATIONAL SECRETARY

Eiichi Takahashi, Tokyo Institute of Technology

TREASURER

Rebecca Lange, University of Michigan

CHAIR, ORGANIC GEOCHEMISTRY DIVISION

Mike Engel, University of Oklahoma

SECRETARY, ORGANIC GEOCHEMISTRY DIVISION

Peggy Ostrom, Michigan State University

DIRECTORS

Thure Cerling, University of Utah
Jochen Hoefs, Universität Göttingen
Albrecht W. Hoffman, Max Planck Institut f. Chemie
K. Vala Ragnarsdottir, University of Bristol
Roberta L. Rudnick, Harvard University
Everett L. Shock, Washington University
Ed Sholkovitz, Woods Hole Oceanographic Institution

EDITORS

GEOCHIMICA ET COSMOCHIMICA ACTA

Frank Podosek, Washington University

GEOCHEMICAL NEWS

Neil C. Sturchio, University of Illinois at Chicago

INTERNET COORDINATOR

Bob Nichols, Washington University

SPECIAL PUBLICATIONS AND

REVIEWS IN MINERALOGY AND GEOCHEMISTRY (CO-EDITOR)

Scott Wood, University of Idaho

THE GEOCHEMICAL SOCIETY

The **Geochemical Society** is a nonprofit scientific society founded to encourage the application of chemistry to the solution of geological and cosmological problems. Membership is international and diverse in background, encompassing such fields as organic geochemistry, high and low-temperature geochemistry, petrology, meteoritics, fluid-rock interaction, and isotope geochemistry. The Society produces a *Special Publications Series*, *The Geochemical News* (this newsletter), the *Reviews in Mineralogy and Geochemistry Series* (jointly with the Mineralogical Association of America), the journal *Geochimica et Cosmochimica Acta* (jointly with the Meteoritical Society), and co-publishes the electronic journal *G³* (jointly with the American Geophysical Union); grants the **V.M. Goldschmidt, F.W. Clarke and Clair C. Patterson Awards**, and, jointly with the European Association of Geochemistry, the **Geochemistry Fellows** title; sponsors the **V.M. Goldschmidt Conference**, held in North America in odd years and elsewhere in even years, jointly with the European Association of Geochemistry; and co-sponsors the Geological Society of America annual meeting and the American Geophysical Union spring meeting. The Society honours first President, F. Earl Ingerson, and our first Goldschmidt Medalist, Paul W. Gast, with the **Ingerson and Gast Lectures**, held annually at the Geological Society of America Meeting and the V.M. Goldschmidt Conference, respectively. The Geochemical Society is affiliated with the American Association for the Advancement of Science and the International Union of Geological Sciences.

Members of the **Organic Geochemistry Division** are individuals with interests in studies on the origin, nature, geochemical significance, and behavior during diagenesis and catagenesis of naturally occurring organic substances in the Earth, and of extraterrestrial organic matter. GS members may choose to be affiliated with the OGD without any additional dues. The OGD presents the **Alfred E. Treibs Award** for major achievements in organic geochemistry, and **Best Paper** awards (student and professional) in organic geochemistry.

Editors' Corner

Neil C. Sturchio, Editor
 Earth & Environmental Sciences
 University of Illinois at Chicago
 845 West Taylor St. (MC-186)
 Chicago, IL 60607-7059 U.S.A.
 Phone: 312-355-1182
 Fax: 312-413-2279
 Email: Sturchio@uic.edu

ASSOCIATE EDITORS

Janne Blichert-Toft, Lyon(France)
Yoko Furukawa, Naval Research Laboratory(USA)
John M. Hanchar, University of Notre Dame (USA)
Mitch Schulte, NASA Ames Research Center (USA)
Angelina W. M. G. Souren, Armadillo Research,
Amsterdam(Netherlands)

ASSISTANT EDITOR

Dolores Sturchio, Naperville, Illinois (USA)

From the President

The 2001 Goldschmidt Conference

As most of you know, Bob Bodnar and I are convening this year's Goldschmidt Conference to be held in Hot Springs, Virginia (USA) at The Homestead. The abstract deadline was in mid-February, and now the program is set and on-line (visit the conference website at <http://www.lpi.usra.edu/meetings/gold2001/>). All abstracts can also be accessed on this site. Attendance at the meeting will set a record for North America, with a whopping 50% increase over the next largest meeting at Harvard two years ago. With attendance near 900, well over half of our membership will be present. Forty-one topical sessions boasting over 750 oral presentations, and nearly 160 poster presentations will cover most aspects of geochemistry, mineralogy, and petrology. Three plenary sessions will help round out the mix. Obviously, I look forward to this time with great anticipation.

The 2001 Board of Directors Meeting

As at all Goldschmidt meetings, the Geochemical Society Board of Directors will gather for a day-long meeting. The meeting will be Saturday, May 19, at The Homestead. This is the only formal opportunity that we have to talk face-to-face as a group all year. Although we are in touch via e-mail and telephone for the rest of the year, this Board meeting obviously provides the most important platform for communication, problem solving, and Society development available to us. We welcome your input. If you have a burning issue that needs attention, let me know about it and, if appropriate, I'll include it in the meeting agenda. Whether it goes on the agenda or not, I'll reply to you so that you know what is going on. My e-mail address is hochella@vt.edu.

Congratulations to the 2001 Medalists and Fellows

Since the last edition of *The Geochemical News*, the GS Medalists and Fellows for this year have been finalized, and if you have not already heard, it is my pleasure to inform you of their names. The Goldschmidt Medal for 2001, the Society's highest honor, goes to Ikuo Kushiro of the University of Tokyo. The Treibs Medal for excellence in organic geochemistry goes this year to John Smith, now retired from the CSIRO, N.S.W., Australia. The Patterson Medal for excellence in environmental geochemistry goes this year to Francois Morel of Princeton University, and the Clarke Medal for outstanding contributions early in one's career goes to Craig Lundstrom of the University of Illinois at Urbana-Champaign. Note that all of these medal recipients will be honored during an afternoon plenary session at the Goldschmidt Conference on Monday, May 21.

The new GS/EAG Fellows for 2001 are Alex Halliday of ETH Zurich, Chris Hawkesworth of the University of Bristol, Williams Jenkins of the University of Southampton, Bo Jorgensen of the Max Planck Institute for Marine Microbiology, Igor Tolstikhin of the Kola Scientific Center in Russia, and

Roland Wollast from the University Libre de Bruxelles. These scientists now join a group that is less than 2% of the membership of GS and EAG. Congratulations to all!



Goings and Comings

I don't need to remind you that the Geochemical Society is run by a very large group of volunteers (60, to be exact!). At the end of 2000, three important officials of the Society stepped down at the end of their three year terms. They are Alexandra Navrotsky of the University of California at Davis, Keith O'Nions of Oxford University, and Ross Taylor of the Australian National University. Alexandra and Keith provided important input on Society issues as members of the Board of Directors, and Ross was our International Secretary, a job of immense importance as we now have members in about 45 countries. I will surely

miss working with all three, as each brought a unique and interesting perspective into Society matters. I have already sent them personal letters of appreciation, but I would like to thank them publicly here for being the champions that they are, and for honoring the Geochemical Society by serving in these vital roles.

At the same time, it is my pleasure to welcome three new Board members. The two new Directors are Roberta Rudnick of the University of Maryland and Edward Sholkovitz of Woods Hole Oceanographic Institute. Our new international secretary is Eiichi Takahashi from the Tokyo Institute of Technology. Over the next three years, they will put many hours into the workings and well-being of this Society, and I wish them well in this journey. Thanks for joining us!

And finally . . .

It's springtime here in the northern hemisphere and The Homestead is preparing for our arrival in late May. I will see many of you there and look forward to the time we will share in hearing about great science and renewing friendships. Have a safe journey!

Warm regards to all,

Mike Hochella
President of the Geochemical Society

Geochemical Society Business

Please address all inquiries and correspondence to:

Seth Davis
Earth & Planetary Sciences
Washington University
One Brookings Drive, Box 1169
St. Louis, MO 63130, USA
Tel. 314-935-4131; Fax. 314-935-4121
e-mail: office@gs.wustl.edu

Open Letter

The Public Library of Science Open Letter (<http://www.publiclibraryofscience.org>) requests that the copyright on any scientific publication should be waived by publishers after six months, so that a public online library could make scientific literature freely available to the scientific community. It is a very generous, mind-teasing initiative, but like most similar initiatives since the advent of electronic publishing, it misses the critical points of electronic publishing.

Ten years ago, a Publisher would be in charge of running a system called a 'scientific journal'. In such a system, the presence of an Editor and peer Reviewers secures the strength of the science and the rigor of the writing, while the Publisher guarantees the professional quality of printing, efficient dissemination, and long-term archival. Publishing used to be in everyone's best interest, or nearly everyone. The Publisher, because he is financially motivated, ensures widespread distribution of the journal among libraries and individual subscribers. The interest of the Author is that the system guarantees a broad potential readership. The interest of the Reader is that a line is drawn between professionally edited literature, presumably of better quality, and grey literature or home publishing, so that he/she does not waste time going through 'low-yield' unclassified information. The Publisher could either be a private company (e.g., Elsevier), an academic institution (e.g., MIT Press), or a scholarly society (e.g., American Geophysical Union). My experience is that, when page charges and subscription rates are compounded, journals published by professional societies are not necessarily cheaper. The difference between these cases is therefore not in the costs of running an office with rents, wages, printing, postage, advertisement, and archival, but that a private Publisher pays shareholders. Shareholders have the bad habit of minding their own business and therefore interfere negatively with scientific publishing. Nevertheless, even though the stranglehold imposed by private Publishers on our libraries over the last ten years by increasing subscription rates may in part be due to shareholders' greed, this is only part of the explanation. The other part is largely a consequence of the booming number of pages in print.

Electronic publishing is modifying the situation in an unexpected manner. The costs of publishing have somewhat decreased but not as much as we wished it had. Most of the costs of running an office that ensures quality science, professional typesetting, and archiving are still there. Tending to a manuscript is still an expensive business, even though electronic submission may reduce labor and postage expenses. An option is that this cost can be footed by the Author (I just finished a CRC book in LaTeX) but then the burden is either transferred to the Author's institution if he/she works during office hours or taken at the expense of his/her private life. Alternatively, using university personnel (e.g., Cambridge) may also lower publishing costs but this trick does not fool anybody.

On the first rumor that the Public Library of Science is coming to life and with the friendly help of funding agencies, most small and medium size libraries as well as most individuals will drop their subscription in a wink (on the argument that we can still read papers six months after publication). Withering cash flow will make scientific publishing less appealing, some Pub-

lishers will inevitably withdraw from the market, and the survival of many core journals may be in danger. Many of us would not cry, but vilifying commercial Publishers will not help because such a move would come with a price. Even the most generous venture, which commercial Publishers never pretended to be, cannot last for very long with an economy in the red. If the present initiative comes through, three points really worry me.

The first problem is dissemination. Libraries and electronic repositories are essentially passive with respect to the Reader. Publishers are active because their monthly paycheck depends on it. A good Publisher goes after me. He sends information to me and does not wait for me to find out on my own where in the electronic jungle the good stuff is hiding. As a seasoned scientist in a Western country, I could probably survive without him, but I fear that a young scientist would loose tremendously if the Publishers did not exist.

If the commercial Publishers are brought down, the second problem will be quality control. Web publishing blurs the limit between literature blue-stamped by an Editor and grey literature. I do not mean that the overall content of commercial scientific journals is all good or that nothing unofficial ever contained anything significant. But we all know that, if we need to find out about top-notch material in our field, we first scrutinize a few very specific journals in an order that does not vary much from one scientist to the next. One more time, the current debate may fool students and young scientists into thinking that the probability of finding good material is about the same everywhere and confuse them in their ways of retrieving information they need. Too much information kills information. The perception that a professionally published scientific journal should be free is wrong: what is free is eventually worth nothing.

The third problem is electronic archiving. If anybody competes with the Publisher for archiving, he will happily relinquish this burden, whether or not he can cash in on the rights. We will then have to go through centralized systems (I can't tell you how expensive they are at this stage). Who would pay for a centralized electronic institution, how would it be run, how much would it cost? How will we handle the question of who pays, how much, and who has access to the electronic shelves?

These problems will inevitably surface with the Public Library of Science initiative and they are not addressed by the proclamation. The initiative clearly requires a drastic change about copyright regulations. I agree that the present situation is quite frustrating but, believe it or not, we can easily make it worse and we should not play dice with the system. The debate of paper versus electronic is financially a red herring. The web is a huge convenience but does not really solve the costs and rates of subscription issues. In order to keep the publishing costs at a reasonable level, professional societies and academic institutions should continue to compete with private publishers. Reining in library expenses also means reining in the expanding number of pages by submitting fewer, denser, and shorter manuscripts. This is the untold part of the conundrum.

Francis Albarede

*President of the European Association of Geochemistry
Senior Editor, Journal of Geophysical Research (Solid Earth)*

***The Geochemical News* Reaches EAG Members**

The Geochemical News is henceforth to be delivered to all members of both The Geochemical Society and the European Association of Geochemistry. This is the result of an agreement reached by the Presidents of the two societies. The extra printing cost is being offset through a change in the grade of the paper (effective with this issue). EAG members are encouraged to contribute announcements, articles, and other items of interest to geochemists for publication in *The Geochemical News*.

EAG Council Officers

President
Francis Albarède
Ecole Normale Supérieure de Lyon
69364 Lyon Cedex 7, France
ph: 33 472 72 84 14
fax: 33 472 72 86 77
albarede@ens-lyon.fr

Vice-President (President-Elect)
Terry M. Seward
Institut für Mineralogie und Petrographie
ETH Zentrum
Sonneggstrasse 5
CH 8092 Zürich, Switzerland
ph 41 1 632 22 27
fax 41 1 632 10 88
tseward@erdw.ethz.ch

Past-President
Albrecht W. Hofmann
Max-Planck Institut für Chemie
Postfach 3060
55020 Mainz, Germany
ph: 49 6131 305 280
fax: 49 6131 371 051
hofmann@mpch-mainz.mpg.de

Secretary
Mark E. Hodson
Department of Soil Science
The University of Reading
PO Box 233, Whiteknights
Reading
RG6 6DW, UK
phone 44 118 931 6557
fax 44 118 931 6660
m.e.hodson@reading.ac.uk

Treasurer
Eric H. Oelkers
Laboratoire de Géochimie
38 rue des 36 ponts
31400 Toulouse, France
fax: 33 5 61 55 87 85
fax: 33 5 61 52 05 44
oelkers@lucid.ups-tlse.fr

Honorary doctorate for Jacques Touret

On Thursday, March 29, 2001, Jacques L.R. Touret received the degree of *Docteur honoris causa* from the Université de Liège in Belgium (www.ulg.ac.be).

Jacques recently retired from the Vrije Universiteit in Amsterdam, The Netherlands, where he was a professor in geology, specialized in fluid inclusions in igneous and metamorphic rocks. He is also well-known for his good sense of humor, his enthusiasm and his energy. You will read more about this in a later issue.

Other recipients of the honorary doctorate were Wilson Harris (writer) from the UK, Eugene Stanley of Boston University, Harry Struijker Boudier of the Universiteit Maastricht in The Netherlands, Harley Moon of Iowa State University, Kazuya Yamanouchi of the Nippon Institute for Biological Science, Nathaniel Lees Gage of Stanford University, Andrew R. Mays of Sheffield University and Albert II, King of Belgium.

Jacques Touret also had the honor of expressing thanks on behalf of all the recipients and his speech made even the King smile. The atmosphere throughout the ceremony was fairly relaxed, in spite of the stately robes and countries' flags, the presence of the King, the choir singing, and the many reporters with their rolling and snapping cameras.

Angelina Souren
Armadillo Research Services
Amsterdam, The Netherlands

Eleventh Annual V. M. Goldschmidt Conference

May 20-24, 2001
The Homestead
Hot Springs, Virginia, USA

Additional information is on the Conference Web site:

<http://www.lpi.usra.edu/meetings/gold2001/>

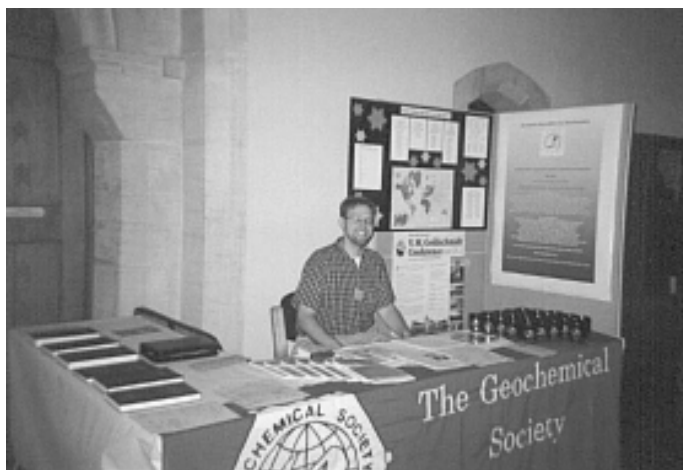

From the Business Office

2001 Membership Drive

Calendar year 2000 closed with 1,416 members. Already, as March 2001 ends, there are 1,473 members for the 2001 calendar year. To continue this trend of progress, I would like to ask members to encourage their students and/or co-workers to join The Geochemical Society. Let them browse through your issues of *The Geochemical News* or refer them to our website at <http://gs.wustl.edu>.

Back Issues of *The Geochemical News*

Past issues of GN are available on our web site at <http://gs.wustl.edu/archives/#NewsLett>. Because of our tight print runs and the GN's accessibility on the web site, late subscribers will not receive calendar year GN back issues *unless they specifically request them*.

Back Issues of *Geochimica et Cosmochimica Acta*

All 2001 GCA subscribers are entitled to all published issues of this year's calendar volume (volume 65). If you notice a skip in your subscription please contact me at the business office and let me know what issue(s) you need. I collect back issue requests and send them off to Elsevier Science on the 15th and 30th of every month. Once Elsevier receives and processes them, expect to wait 6 to 8 weeks for your back issue(s) to arrive. Unfortunately, there have been occurrences of back issue requests not arriving in this time frame. So that I can monitor the time required for each request, please send a brief e-mail to the business office letting me know when your request arrives.

Geochemical Society Booth at 2001 Goldschmidt

As in years previous, The Geochemical Society will be manning an exhibition booth at this year's Goldschmidt Conference in Hot Springs, Virginia. Please take a few moments to check out all of the exhibitors and don't forget to stop by our booth. It will be an excellent chance to meet everyone I've been working with over the last year, as well as a chance for you to see the guy who is behind all those e-mails. See you in Virginia!

Seth Davis
GS Business Manager

Q & A

Q. As a GS Member, do I have access to GCA On-line?

A. No. Online access to full text articles for *Geochimica et Cosmochimica Acta* is available only to those readers whose library has either subscribed to GCA via ScienceDirect Digital Collections, or has a current print subscription to GCA and has registered for ScienceDirect Web Editions. GS is currently examining the possibility of having on-line access to subscribing GS members. If this comes to fruition, it will be announced in a future issue of *The Geochemical News*.

Q. Do I have a GS Membership Number?

A. No. Back in December 1999, the Business Office changed its database so that it no longer required Membership Numbers. If you are a member registering for the Goldschmidt Conference, just check the 'yes' box, or if you are registering on-line for the Spring AGU meeting, indicate that you are a GS member then use the following 8-digit number: "12345678" in the membership number box. The conventioners may then contact the Business Office to verify.

*The Geochemical Society
and Mineralogical Society of America
present*

Short Course

Molecular Modeling Theory and Applications in the Geosciences

Saturday and Sunday
May 19 and 20, 2001
(precedes Goldschmidt Conference)

Hotel Roanoke and Conference Center
Roanoke, Virginia, USA

This course will focus on techniques and applications for modeling a wide variety of problems in mineralogy and geochemistry. Those interested in using molecular modeling in research or understanding papers in computational chemistry should attend.

Randall T. Cygan and James D. Kubicki, Organizers

www.sandia.gov/eesection/GScourse.htm

Short Course Registration Form

Molecular Modeling Theory and Applications in the Geosciences

Roanoke, Virginia, U.S.A—May 19-20, 2001

Complete and return this registration form to the Geochemical Society Business Office via e-mail, fax, regular mail, or by telephone. An electronic version of the form can be obtained through links on the short course web page (<http://www.sandia.gov/eeselector/GScourse.htm>). Registration is limited to 120 people. Payment must accompany this form, which will be fully refunded if cancellation is received in writing by May 1, 2001.

Short Course Registration
Geochemical Society
Washington University
Department of Earth and Planetary Sciences
One Brookings Drive, CB 1169
St. Louis, MO 63130-4899

Voice: 314-935-4131 (M-F, 9:00 AM to 4:00 PM, U.S. Central Time)

Fax: 314-935-4121

E-mail: gsoffice@gs.wustl.edu

Name _____

Address _____

Telephone (Voice) _____ (Fax) _____

E-mail _____

Mark the appropriate registration category [X] and write the appropriate fee on the cost line.

 Professional registration \$200 Student registration \$150

Amount Due \$ _____

Amount Enclosed (Indicate payment method and amount of payment enclosed) Enclosed is a check (in U.S. \$ drawn on a U.S. bank) or money order

Charge my Visa Mastercard American Express Diner's Club card
Your credit card will be charged when the registration form is received

(Card number)_____
(Name on card — please print)_____
(Signature)_____
(Expiration date)

Research Snapshot



Buggers in The Netherlands: fungi, bacteria and geochemistry

In case you didn't know: I have this thing with fungi. It dates back to a past life, in which I investigated the phenomenon of marine cerium anomalies. Yes, I have a thing with cerium and redox reactions too. Of course, if you're interested in cerium, you're automatically also interested in cobalt and manganese. And manganese led me to fungi.

As I was going through the literature then, looking into culturing bacteria, manganese-oxidizing fungi kept jumping off the pages. Almost literally. How could I ignore that? I investigated further and discovered a whole new world. Incidentally, did you know that there are four correct ways to pronounce the word 'fungi' in English? Fungi, fascinating in many ways, are still often overlooked, but I'm not the only one interested in these organisms and their role in biogeochemical cycles.

A few years ago, a publication in *Nature* described how open tunnels with a constant diameter of 3 - 10 micrometer had been found in weatherable minerals from a Swedish podzol (Jongmans et al., 1997). Occasionally, fungal hyphae were visible inside these tunnels. Nico van Breemen of Wageningen University in The Netherlands was one of the authors of that article. I later attended a talk he gave at Utrecht University, for the Dutch Geochemical Circle. At one point he enthusiastically revealed a slide and, beaming with pleasure, exclaimed something like "Just look at the buggers! See how they go straight for the apatite!" I smiled. I realized he had it too. The thing with fungi. Fungi are so opportunistic, you sometimes wish you were a fungus. Fungi (and bacteria as well) make use of whatever is available and thrive on it. Their appetite for apatite is only one example. I burst out laughing a few years ago when I spotted the title of an article. "Fungal growth on buckminsterfullerene." You make it; they'll use it. And they'll cooperate too, if it suits them. They form symbioses.

Ectomycorrhizas are examples of such symbioses. Ectomycorrhizas are associations between mycorrhizal fungi and the roots of plants. The host plants are usually woody perennials. Wageningen University, traditionally focused on agriculture, has always done a lot of work on fungi, for instance on the infamous potato blight fungus *Phytophthora*. In 1998, Wageningen University started a program called 'Rock-eating Mycorrhiza: Where, why, how?' Three projects are currently being carried out within this program: 'Occurrence of REM and their contribution to mineral weathering' by Ellis Hoffland, 'Do REM provide protection against toxic aluminium?' by Laura van Schöll and 'Mineral weathering by ectomycorrhizal fungi' by Renske Landeweert.

At the moment, Ph.D. student Renske Landeweert is

developing molecular methods for identification and quantification of fungi in soil. Next, she'll carry out a number of experiments focused on the contribution of ectomycorrhizal fungi to weathering processes. The aim of her project is 1) to identify ectomycorrhizal fungi in the field that excrete organic acids and weather minerals, 2) to quantify the presence of ectomycorrhizal fungal weatherers in soil, 3) to clarify some of the weathering mechanisms involved, and 4) to determine whether it is the tree or the fungus that controls this weathering process.

If you want to learn more about this topic, watch the journal *Trends in Ecology and Evolution*. The May issue will contain a review article about mineral weathering and ectomycorrhizal fungi.

The first paragraph may have led you to expect hearing something related to manganese as well here. To that end, let's transfer our attention to other little buggers: manganese-oxidizing bacteria. On March 1, 2001 Liesbeth de Vrind-de Jong, of Leiden University, presented a research overview at Utrecht University. The talk drew a small but fascinated audience. The following is an excerpt of that talk.

Microbial Mn oxidation can take place indirectly, for instance by pH increase or oxygen production by photosynthesis or directly, notably by enzymes. In the latter case, research on Mn-oxidizing bacteria involves two approaches: 1) isolating, identifying and working with the enzyme and 2) isolating and working with the encoding genes. What approach is taken, depends on the case. Some enzymes are easy to work with, while others are almost impossible to isolate and therefore basically force researchers to work with the genes.

Bacterial manganese-oxidizing factors (MOFs) turn out to resemble multicopper oxidases, such as laccase. They contain similar amino acid sequences. The oxidation process is definitely copper-dependent: addition of Cu stimulates oxidation. Recent research shows that all MOFs identified so far contain similar Cu-binding sites composed of, amongst others, conserved histidine residues.

Pseudomonas putida is an example of a Mn-oxidizing bacterium Leiden University is currently working on. It's gram-negative and Mn oxidation is extracellular. Its MOF is difficult to isolate and the gene approach was therefore taken in this case. The MOF somehow appears to be part of a larger complex.

The next steps in this line of work would involve 1) to produce the multicopper oxidase in large amounts and prove that they do oxidize Mn, 2) to look at the Mn-oxidizers, such as wood-rotting fungi, and investigate the similarities and differences in the Mn-oxidizing systems, 3) to go into the field: water and soil and estimate the contribution of the MOFs in Mn oxidation, and 4) to develop biotechnological applications of the outcome.

Snap. That was the sound of the shutter closing. Acknowledgements go to Renske Landeweert and Liesbeth de Vrind-de Jong for their contribution to this snapshot.

Angelina Souren
 Armadillo Research Services
 Amsterdam, The Netherlands
 Continued on page 13

MINERALOGICAL ASSOCIATION OF CANADA
SHORT COURSE

Principles and Applications of Laser Ablation-ICP-Mass Spectrometry in the Earth Sciences

ST. JOHN'S, NEWFOUNDLAND

26-27 MAY 2001

(HELD IMMEDIATELY PRECEDING THE JOINT ANNUAL MEETING OF
THE GEOLOGICAL ASSOCIATION OF CANADA – MINERALOGICAL
ASSOCIATION OF CANADA)

LASER ablation-ICPMS is arguably the most exciting
new analytical development in geochemistry in the
last decade, opening up approaches to pure and
applied geologic problems that were only dreamed
of before. The goal of this course is to teach graduate
students and post-graduate researchers how laser
ablation-ICPMS works, what is being done in the
Earth sciences with the method now, and what could
be done in the future. It will appeal to all those Earth
scientists who are interested in solving geologic
problems with chemical data. Material will be pre-
sented at the level of understanding of most graduate
students in the Earth sciences and will be assembled
in a short-course volume.

Technical topics discussed include: Nd-YAG and excimer laser
instrumentation; laser beam delivery systems; ablation cell design;
quadrupole, magnetic sector and time-of-flight ICPMS instru-
mentation; collision cell technologies; sample preparation; data
acquisition, calibration and quantification strategies; laser ablation
phenomena and element fractionation.

Examples of Earth sciences applications: whole rock geochemistry
using fusion disk analyses; lithophile element studies of silicate
and oxide minerals in the mantle and crust; noble metal element
studies of sulphides, oxides and metals in ores and rocks; exper-
imental mineral-melt partitioning; melt inclusions and magmatic
processes; fluid inclusions and ore genesis; metamorphic minerals
and diffusion-rate processes; trace-element geothermometry/
geobarometry; environmental pollution tracing and monitoring;
radiogenic isotope systematics of minerals; U-Pb accessory
mineral geochronology.

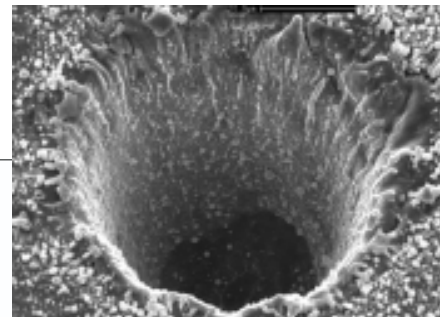
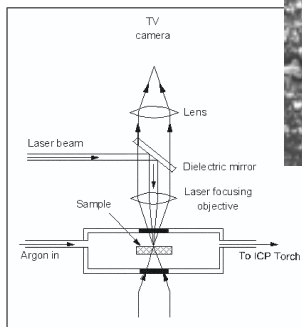

Registration costs: CAN\$250 for professionals and CAN\$150
for students (includes short-course volume and two cold lunches).

To register and for other information,
visit the St. John's 2001 GACMAC website at
[www.geosurv.gov.nf.ca/stjohns 2001](http://www.geosurv.gov.nf.ca/stjohns2001)
or contact Dr Paul Sylvester at pauls@sparky2.esd.mun.ca
for answers to specific questions.
Online registration will commence on 1 March 2001.

Scheduled Lecturers

Detlef Günther, Professor für Analytische Chemie und Spurenanalytik,
ETH Zürich, Switzerland

Simon Jackson, Lecturer, School of Earth Sciences, Macquarie
University, Australia

Jan Kosler, Lecturer, Department of Geochemistry, Charles University,
Czech Republic; and Research Associate, Department of Earth Sciences,
Memorial University of Newfoundland

Henry Longerich, Professor Emeritus, Department of Earth Science,
Memorial University of Newfoundland

Nuno Machado, Professeur associé et Agent de recherche et de
planification, Sciences de la Terre, Université du Québec à Montréal

Paul Mason, Research Officer, Faculty of Earth Sciences, University
of Utrecht, The Netherlands

Marc Norman, Senior Research Fellow, School of Earth Sciences,
University of Tasmania, Australia

Paul Sylvester, Associate Professor, Department of Earth Sciences,
Memorial University of Newfoundland

Geoff Veinott, Research Scientist, Department of Fisheries and Oceans,
Environmental Sciences Division, Northwest Atlantic Fisheries Centre

Student Registration Grants

A limited number of awards is available to students to cover the
registration fee. Applicants should send a brief statement outlining their
interest in the short course and explaining how their attendance will
enhance their academic studies or research to Dr Paul Sylvester by email
at pauls@sparky2.esd.mun.ca. APPLICATIONS MUST BE RECEIVED
BY 1 MARCH 2001.



Mineralogical
Association of Canada
Association minéralogique
du Canada



John H. Reynolds (1923-2000)

Almost 50 years ago a young Assistant Professor in the Department of Physics at the University of California, Berkeley, decided that advances in rare gas dating techniques could be realized by exploiting “static” mass spectrometry of rare gas isotopes. As used in this sense, “static” refers to the procedure of admitting the gas sample into the mass spectrometer and performing the analysis *in a closed system with the pump valve closed*. We all take this for granted today, but this capability did not exist until John Reynolds developed it. John built and exploited an all glass, 60° magnetic sector gas-source mass spectrometer with ultra-high vacuum valves that was bakeable to 300 °C and clean enough to operate in static mode, a set of design characteristics that even today is described as a “Reynolds-type” mass spectrometer.

The immediate payoff was a major improvement in sensitivity and background, enabling the analysis of smaller and, for geochronology, younger samples. This led, among many other things, to the discovery of extinct radioactivity and various isotopic anomalies in meteorites and to great improvements in the K-Ar dating technique (which led eventually to the paleomagnetic time scale, a key factor in acceptance of the theory of sea floor spreading, and so on). Following the lead of Josef Zähringer, who first described the technique of stepwise heating, Reynolds with Peter Jeffery showed that ^{128}Xe produced by neutron activation of ^{127}I was correlated with meteoritic radiogenic ^{129}Xe , which led to the development of the I-Xe scheme and the invention of the ^{39}Ar - ^{40}Ar dating method by Craig Merrihue and Grenville Turner, both members of the Reynolds research group. Half a century later, the Reynolds mass spectrometer remains the basis of rare gas studies world-wide. Its

development marks the birth of rare gas geochemistry as a new scientific discipline in the planetary- and geo-sciences, and the scientific ramifications of the work of John Reynolds and his colleagues, collaborators and students are so extensive that it is hard to imagine what geochemistry and cosmochemistry would be like without them.

Sadly, Professor John Reynolds died unexpectedly November 5th after a brief illness. John was born into an academic family in Cambridge, Massachusetts on April 3rd 1923 and was undoubtedly predisposed toward academic life by his home environment. His father and mother were educated at Harvard and Wellesley, respectively. His father’s interests were the Irish Literary Renaissance and American Folklore, and he taught at various colleges, primarily in the Boston area. Both parents had numerous articles published in newspapers and magazines. Most of John’s childhood was spent in Cambridge, where he was educated in the public school system through high school, and obtained an AB degree in Electronic Physics at Harvard in 1943. He served in the U.S. Navy as a specialist officer (Ensign through Lieutenant) in ordnance from 1943-1946. After leaving the Navy, John began his graduate studies at the University of Chicago, led there by his interests in the Manhattan project. With his good friend Richard Hayden, he joined the mass spectroscopy group under the leadership of Mark Inghram, whom John described as “a very hard-driving experimentalist”. While working with Inghram, John became strongly influenced by an emerging group of geochemists and cosmochemists with interests in meteorites, that included Harold Urey, Harrison Brown, Hans Suess and eventually Clare Patterson, George Tilton, and Sam Epstein. John was also fortunate to experience first-hand the large impact and influence Enrico Fermi had on the Chicago graduate students. With Inghram he discovered the double β -decay of ^{130}Te by observing excess ^{130}Xe in natural tellurium ores and established limits for the double β -decay half-life that supported Dirac’s antineutrino theory. Also while at Chicago, John discovered a long-lived isotope of krypton, ^{81}Kr , which later became the basis of the most precise cosmic ray exposure dating method for meteorites and lunar rocks.

Upon completion of his PhD in 1950, John moved from Chicago to Berkeley, accepting an Assistant Professorship in the Department of Physics. He remained at Berkeley for his entire professional career, retiring as Professor Emeritus in 1989. He was the recipient of numerous awards in recognition of his scientific achievements: the John Wetherill Medal of the Franklin Institute (1965), the J. Lawrence Smith Medal of the National Academy of Sciences (1967), the Golden Plate Award of the American Academy of Achievement (1968), the Meteoritical Society’s Leonard Medal (1973), and the NASA Exceptional Scientific Achievement Medal (1973). He was elected to membership in the National Academy of Sciences in 1968. He was a Guggenheim Fellow, a NSF Senior Postdoctoral Fellow and was elected a Fellow of the American Academy of Arts and Sciences in 1986 and a Geochemistry Fellow of the Geochemical Society and European Association of Geochemistry in 1996. John also served as Chairman of the Department of Physics at Berkeley from 1984 to 1986, and was awarded the Berkeley Citation in 1988.

John was an excellent teacher, dedicated to the interests and careers of his students. If you pressed him, hard, he might admit to having a reputation for developing young scientists. Others would say John had a "magic touch". He provided an environment for his students, post docs, and visitors that encouraged independence, the development of self-reliance, diligence, and unselfish cooperation. The latter is best exemplified by his unstinting willingness to provide guidance whenever needed – his door was always open – and the two sabbaticals John spent in Portugal and Brazil establishing geochronology labs and for which in 1987 he received Doctor, Honoris Causa, from the University of Coimbra, Portugal. Indeed, the Berkeley rare gas laboratory was a good place to be and to learn.

John was an avid hiker, camper, and swimmer. Later in life, perhaps attracted by the independence offered by sailing and the need for self-reliance and diligence that it requires, John became an accomplished skipper. He spent much of his free time sailing his boat *Johnmanx*, locally in San Francisco Bay and afar, with trips to the inland waterways and fjords of Alaska (twice) and summer voyages up and down the eastern seaboard using Lake Michigan as a port of entry. John was also very fond of music, particularly the structure and subtleties of harmony, and was a longtime member of the Faculty Club Monk's Chorus and an accomplished harmonica player, the latter used judiciously to smooth those rough moments often encountered at sea and in the field. John was a mentor not only in science, but in our personal lives as well. He was an unpretentious man of ethics, honor, principle and morality, who was thoroughly dedicated to the University of California, its faculty and its students.

For all who have walked, sailed, fished, sang, or just watched him at the helm of a mass spectrometer, there will be a deep sense of loss. But "Death is nothing at all. It does not count. I have only slipped away into the next room. Nothing has happened. Everything remains exactly as it was. I am I, and you are you, and the old life that we lived so fondly together is untouched, unchanged." As put most eloquently by Grenville Turner, John Reynolds was "a gentle man of science". In a very real sense, John and his influence are immortalized by his scientific "children", his students, postdocs, and other visitors who came to Berkeley to learn, and their children, and their children. In fostering his scientific descendents he has been as prolific as in scientific discovery.

B. Mack Kennedy
Center for Isotope Geochemistry
Lawrence Berkeley National Laboratory
Berkeley, California

Frank A. Podosek
Department of Earth and Planetary Sciences and
The McDonnell Center for Space Science
Washington University
St. Louis, Missouri

Organic Geochemistry Division
of the Geochemical Society

GEOCHEMICAL AND ENVIRONMENTAL APPLICATIONS OF MOLECULAR ISOTOPIC ANALYSIS

American Chemical Society Meeting
Chicago, August 26-30, 2001

•*Petroleum Exploration and Production (1)*

Isotopic compositions of individual compounds in crude oils, gases, and associated waters; source-rock paleoenvironment

•*Global Biogeochemical Cycling (2)*

Paleoclimate; ¹⁴C age dating; marine trophic studies; deep sediment contributions; black carbon in ice; early life

•*Ecological Tracers and Environmental Monitoring (3)*

Nutrients in watersheds; microbial consortia; wetland processes; contaminant degradation; bioremediation

Organizers:

Ken Peters (1)

ExxonMobil Upstream Research Company
P.O. Box 2189, Houston, Texas 77252-2189
Tel: 713-431-4637, Fax: 713-431-6310
E-mail: ken_peters@email.mobil.com

Peggy Ostrom (2)

Michigan State University, Dept. of Geological Sciences
206 Natural Science Building, East Lansing, MI 48824-1115
Tel: 517-353-9768, Fax: 517-353-8787
E-mail: ostrom@pilot.msu.edu

Bob Dias (3)

Old Dominion University
Department of Chemistry and Biochemistry
Norfolk, Virginia 23529
Tel: 757-683-4093, Fax: 757-683-4628
E-mail: rfdias@odu.edu

The electronic abstract deadline for the Chicago meeting is
April 30, 2001, at <http://oasys.acs.org>

An Obituary for Samuel S. Goldich

Goldschmidt Medal winner in 1983, Samuel Stephen Goldich died 20 December 2000 at his apartment in Applewood, Colorado (a suburb of Denver), less than a month before his 92nd birthday. Sam, as he was widely known, received early fame with his 1938 paper in the *Journal of Geology* on rock weathering based on his Ph.D. thesis, an amazing paper that continued to receive citations into the 1990s, more than 50 years later. In short, he determined that the resistance of igneous minerals to weathering was the inverse of the Bowen Reaction Series, that is minerals crystallized at lower temperatures were more resistant to weathering than those crystallized at higher temperatures (and pressures) (e.g., the most resistant was quartz followed by orthoclase, etc.), a sequence that became known as the Goldich Stability Series. A second, two-part widely utilized paper was published by Sandell and Goldich (1941) on the trace-element concentrations in igneous rocks. This pioneering paper introduced the dithizone colorimetric analytical technique for trace-element determination to earth science and resulted in some of the most precise trace-element data in extent at the time and for decades thereafter.

Considering this history, it was perhaps inevitable that Sam would investigate the effect of weathering on such things as K-Ar and Rb-Sr dating of biotite (Goldich and Gast, 1966) and zircon (Stern et al., 1966). A very important paper with Mudrey (1972) using dilatancy to help explain the discordance of the U-Th-Pb ages in zircons never received the acclaim it deserved probably because of its original publication in a Russian book. The theory says that, as the pressure on minerals and rocks is released through uplift and erosion, they expand and make lead that is not in the structure accessible for removal by crustal fluids. No biography of Goldich would be complete without mention of Sam's interest in the 3,500-myr.-old rocks of the Minnesota River Valley which originally appeared to be 3,800 myr. old (see Goldich et al., 1970). He ended his research career with a very important paper on the air abrasion method of preparing zircons for U-Th-Pb dating (Goldich and Fischer, 1986) that has become much used for Pb isotope tracer work as well as zircon dating. Sam received the Department of Interior Distinguished Service Award in 1965. He was a founder of the Institute of Lake Superior Geology and received its first Goldich Award in 1980. He was a fellow of the American Geophysical Union, Mineralogical Society of America, and Geological Society of America.

S.S. Goldich received an AB from the University of Minnesota in 1929 and eventually a Ph.D. in 1936. In between, he earned an M.A. from Syracuse University in 1930 (and was to receive their Alexander Winchell Award in Geology in 1977). He served World War II in the U.S. Geological Survey (U.S.G.S.) in exploration and study of laterite and bauxite in a number of unusual locations that eventually resulted in a series of papers during a second tour with the U.S.G.S. in 1947 and 1948. Sam rejoined the University of Minnesota in 1948 and became Professor and Director of the Rock Analysis Laboratory the follow-

ing year and until his departure in 1959 (and was to receive the Minnesota Outstanding Achievement Award in 1985). During this period and in collaboration with Alfred Nier of the University of Minnesota, Sam organized a potassium-argon facility in the Department of Geology with Halfdon Baadsgaard. He also had refined a long time interest in the origin of iron ores which resulted in a couple of important papers (Lepp and Goldich, 1959, 1964).

Goldich joined the U.S.G.S. again and became the founding Branch Chief of the famous Branch of Isotope Geology in 1960, now defunct. Initially, the Branch was located at the old National Bureau of Standards (NBS) site on Connecticut Avenue and Van Ness in Washington, D.C. (Now the site of the University of the District of Columbia). This location also allowed Goldich to make a close association with Bill Shields of the NBS (now called the National Institute of Standards and Technology) who was involved in using mass spectrometry for re-determining atomic weights and calibrating the uranium isotopic composition of nuclear fuels. The association resulted in much upgrading of the instrumentation in the Branch plus the building of new equipment known as Shields Mass Spectrometers. This led the late Paul Gast to say that Shields was the most valuable employee in the Branch of Isotope Geology, and the U.S.G.S. didn't even have to pay him. Most equipment was obtained as a result of cooperation with other organizations. Lorin Stieff, for example, arranged an investigation of uranium series disequilibrium in soils that freed up money for a 12-inch Shields mass spectrometer and the building of a clean laboratory for isotopic investigations in Denver.

After his tour as Chief of the Branch of Isotope Geology, Goldich left the U.S. Geological Survey again and from 1964-1965 joined Pennsylvania State University as Professor of Geology and Geochemistry and Director of the Mineral Constitution. Sam moved to the State University of New York at Stony Brook as Professor of Geology from 1965 to 1968 at which time he oversaw the building of another isotope laboratory. Restless, he moved to Northern Illinois University in 1968 as Professor of Geology until his retirement in 1977 as emeritus and where he organized yet a fourth isotope geology laboratory.

No discussion of Sam Goldich would be complete without some mention of his famous personality. Although Sam could be very generous, he was prone to giving unsolicited good advice or opinions. This advice or opinions was often given in a tone that the recipient would take as criticism or, even, condemnation. Perhaps all those who were close to Sam, and even many more distant, experienced this at some time or other. He was prone to allergies that did not improve his disposition. I recall once in a class when he repeatedly asked some question in an increasingly agitated and loud voice punctuated by his blowing his nose as one student after another he called upon couldn't answer it. He finally said with a cute smile, "This class sure is stupid when I don't feel good." However, he left an ill will with many which probably accounts for this remarkable scientist not winning more honors than he did. But there were a lot of us that learned to overcome Sam's outbursts and to regard him as a friend and wonderful scientist.

For a more extensive obituary and complete bibliography of S.S. Goldich, point your browser at a web site maintained by Gil Hanson:

<http://www.geo.sunysb.edu/ssgoldich/>

Bruce R. Doe

References Cited

Goldich, Samuel S., 1938. A study in rock weathering. *Journal of Geology* **46**, 17-58.

Goldich, S.S. & Fisher, L.B., 1986. Air-abrasion experiments in U-Pb dating of zircon. *Chemical Geology* **58**, 195-215.

Goldich, S. S. & Gast, P. W., 1966. Effects of weathering on the Rb-Sr and K-Ar ages of biotite from the Morton Gneiss, Minnesota. *Earth and Planetary Science Letters* **1**, 372-375.

Goldich, S.S., Hedge, C.E. & Stern, T.W., 1970. Age of the Morton and Montevideo gneisses and related rocks, southwestern Minnesota. *Geological Society of America Bulletin* **81**, 3671-3696.

Goldich, S. S. & Mudrey, M. G., Jr., 1972. Model' rasshireniya dlya ob'yasneniya nesoglasnykh urano-svintsovykh vozrastov v tsirkonakh; Dilatancy model for explaining discordant uranium-lead zircon ages. *Ocherki sovremennoy geokhimii i analiticheskoy khimii*, 415-418.

Lepp, Henry & Goldich, Samuel Stephen, 1959. The chemistry and origin of iron formations. *Economic Geology and the Bulletin of the Society of Economic Geologists* **54**, 1348-1349.

Lepp, Henry & Goldich, Samuel S., 1964. Origin of Precambrian iron formations. *Economic Geology and the Bulletin of the Society of Economic Geologists* **59**, 1025-1060.

Sandell, Ernest Birger & Goldich, Samuel Stephen, 1941. The rarer metallic constituents of some American igneous rocks; Part 1. *Journal of Geology* **51**, 99-115, (Part 2), 167-189.

Stern, T. W., Goldich, S. S., & Newell, M. F., 1966. Effects of weathering on the U-Pb ages of zircon from the Morton Gneiss, Minnesota. *Earth and Planetary Science Letters* **1**, 369-371.

visit The Geochemical Society's web site

<http://gs.wustl.edu>

Continued from page 8

References

Brouwers G.J., de Vrind J.P.M., Corstjens P.L.A.M., and de Vrind-de Jong E.W. (1998) Involvement of genes of the two-step protein secretion pathway in the transport of the manganese-oxidizing factor across the outer membrane of *Pseudomonas putida* strain GB-1. *American Mineralogist*, **83**, 1573-1582.

Brouwers G.J., Vijgenboom E., Corstjens P.L.A.M., de Vrind J.P.M. and de Vrind-de Jong E.W. (2000) Bacterial Mn²⁺-oxidizing systems and multicopper oxidases: an overview of mechanisms and functions. *Geomicrobiology Journal*, **17**, 1-24.

Jongmans A.G., Van Breemen N., Lundström U., Van Hees P.A.W., Finlay R.D., Srinivasan M., Unestam T., Giesler R., Melkerud P.-A., and Olsson M. (1997) Rock-eating fungi. *Nature*, **389**, 682-683.

R. Landeweert, Hoffland E., Finlay R.D., Kuyper Th.W. and Van Breemen N. (2001) Linking plants to rocks: Ectomycorrhizal fungi mobilize nutrients from minerals. *TREE*, **16** (5), 248-254.

URL for information about mycorrhizas at The Microbial World: <http://helios.bto.ed.ac.uk/bto/microbes/mycorrh.htm>

URL Third International Conference on Mycorrhizas (ICOM3), Adelaide, Australia, July 8-13: http://www.waite.adelaide.edu.au/Soil_Water/3icom.html

URL Wageningen University soil research: <http://www.benp.wau.nl/research/>

Eleventh Annual V. M. Goldschmidt Conference

May 20-24, 2001
The Homestead
Hot Springs, Virginia, USA

Additional information is on the Conference Web site:

<http://www.lpi.usra.edu/meetings/gold2001/>

European Research Facilities: The European Synchrotron Radiation Facility (ESRF Grenoble)

Philippe Gillet
Ecole Normale Supérieure de Lyon, France



Over the past twenty years the use of synchrotron radiation has significantly improved our understanding of the Earth's interior. The parallel development of high-pressure techniques and third-generation synchrotron sources, such as the one installed in Grenoble (France), has led to outstanding results concerning the mineralogical and chemical composition of the Earth's mantle and core. After a brief description of the Grenoble X-ray source, I will present a few scientific highlights that emphasize the variety of experiments that can be conducted for probing the state and behavior of materials at pressure and temperature conditions relevant to the deep mantle and core.

Synchrotron radiation is an intense white beam of electromagnetic radiation, whose spectrum ranges from hard X-rays to microwaves. It is generated by accelerating beams of charged particles (positrons with 6 GeV energy at the ESRF) to relativistic velocities. The X-ray radiation produced by the accelerated particles has an exceptional intensity characterized by a flux several orders of magnitude greater than that available from the most powerful laboratory sources. This high brilliance in combination with high-pressure devices, such as laser-heated diamond anvil cells (LHDAC) and multi-anvil presses (HEMLEY, 1998; RUBIE and MACKWELL, 2001) that have been adapted to the synchrotron beam lines (Fig. 1), have opened up new experimental possibilities for the study of matter at ultra-high pressures and temperatures. Among the various types of measurement that can be made with such facilities, I will emphasize the following: X-ray diffraction and X-ray spectroscopy, which provide local probes for atomic environments in solids and liquids, and inelastic scattering of X-rays. At the ESRF, two beam lines (ID09 and ID30) are dedicated exclusively to the study of materials at high pressures and temperatures and are essentially fo-

cusced on diffraction experiments. Other beam lines are used for conducting all other types of measurements at extreme P and T conditions. A detailed description of the synchrotron and all its beam lines can be found at the ESRF website <http://www.esrf.fr>.

Angle dispersive diffraction in the Diamond Anvil Cell

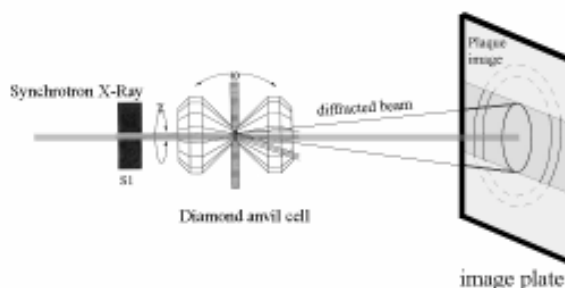

Figure 1. Typical set-up for performing high-pressure X-ray diffraction experiments in a diamond anvil cell.

One of the most direct ways of determining the composition of the mantle and core is to compare seismic wave velocities and densities as a function of depth with similar properties for candidate minerals at high pressure and temperature. The first step is to experimentally synthesize these minerals. In a second step, the properties of the phases are measured at pressure and temperature conditions characteristic of the mantle and core. In the past decade, European groups in collaboration with the staff of the ID09 and ID30 beam lines at the ESRF have developed such measurements using both large-volume press devices and LHDAC. For a survey of the most important results of this research, the reader can consult the highlights published every year by the ESRF.

Diffraction measurements on single crystals or powders are classical tools for mineral identification and monitoring of phase transitions induced by pressure and temperature changes that can also be used to infer the equation of state (EoS) of solids and liquids, a relationship that links density to P and T. Such measurements have been carried out for (Mg,Fe)SiO₄-perovskite and (Mg,Fe)O-magnesiowüstite, two minerals believed to be the major components of the lower mantle. The LHDAC installed at the ESRF has provided the first determination of the densities of these minerals at P and T conditions in the range of those of the lower mantle up to 100 GPa and 3000 K (FIQUET et al., 1998). These experiments have confirmed that a mixture of perovskite and magnesiowüstite has the required density to explain the density profile derived from seismic data. Similar data are now available for a great variety of other minerals including the silica polymorph olivine and its high-pressure polymorphs wadsleyite and ringwoodite. The effect of small amounts of water on the EoS has also been measured.

Figure 2. (P,T) diagram showing the conditions under which the stability and equation of state of MgSiO₃-perovskite have been measured using synchrotron X-ray diffraction and both laser-heated diamond anvil cell and large-volume press devices.

The density of the Earth's outer core has been known for a long time to be less than that of a pure Fe-Ni liquid. The core is thus expected to contain up to 10-15 wt.% of light elements (H, C, N, O, Si and S). Deciding which of these elements can be alloyed with Fe can be done using EoS measurements on candidate liquid alloys. Measuring the density of such liquids is an experimental challenge. Recently, however, groups at ENS Lyon, IPG Paris, and the ESRF have obtained the first static measurements of the density of metallic liquids in the Fe-S system up to 7 GPa and 2300 K (SANLOUP et al., 2000). Density has been derived from X-ray absorption experiments carried out with a large-volume press installed on the ID30 beam line at the ESRF. Because the absorption of X-rays is directly related to the density of the liquid, changes in absorption as a function of pressure can provide the EoS of the liquids. It has been shown that increasing the amount of S in liquid-Fe decreases the bulk incompressibility by -2.5 GPa per wt.% of S. Such data, though at this point obtained only at "low pressures", provide strong constraints on the presence and amount of S in the core of small planetary bodies, and, assuming one can extrapolate to higher pressures, in the Earth's core as well.

Measuring acoustic velocities of minerals at high pressures is also an essential tool for comparison with global velocity models of the Earth. Such data can now be obtained at very high pressures using the so-called inelastic X-ray scattering technique. Such experiments investigate the way in which the X-ray beam is scattered by the acoustic waves travelling through the compressed sample. Over the past few months, the first results have been obtained jointly by the Paris group and members of the ESRF (FIQUET et al., 2001) on hcp-Fe, the presumed structure

of iron in the Earth's inner core. It is shown that between 19 and 110 GPa the longitudinal wave velocity (V_p) increases from 7000 to 8800 ms⁻¹. Extrapolation of these results to higher pressures seems to indicate that the Earth's inner core is slightly lighter than pure hcp-Fe, suggesting either a different structure for iron or the presence of light elements in the alloy constituting the core of the Earth.

Numerous other measurements involving the coupled use of synchrotron radiation and high-pressure techniques are currently carried out at the ESRF and other third-generation synchrotron sources around the world (Advanced Photon Source in the United States, SPRING-8 in Japan) with the purpose of examining the behavior and properties of planetary materials including, in addition to minerals and melts, simple compounds such as H, He, Ar, CO₂, H₂O, and CH₄, which are present in the deep Earth and the interiors of other planets of the solar system.

- Fiquet G., Andrault D., Dewaele A., Charpin T., Kunz M., and Hausermann D. (1998) P-V-T equation of state of MgSiO₃ perovskite. *Phys. Earth Planet. Int.* **105**, 21-32.
- Fiquet G., Badro J., Guyot F., Requardt H., and Krisch M. (2001) Sound velocities of iron to 110 Gigapascals. *Science* **291**(468-471).
- Hemley R. J. (1998) Ultra-high pressure Mineralogy : Physics and Chemistry of the Earth's deep Interior. In *Reviews in Mineralogy*, Vol. 37 (ed. P. H. Ribbe). Mineralogical Society of America.
- Rubie D. and Mackwell S. (2001) European Research Facilities: The Bayerisches Geonstitut. *The Geochemical News* **106**, 16-17.
- Sanloup C., Guyot F., Gillet P., Fiquet G., Mezouar M., and Martinez I. (2000) Density measurements of liquid Fe-S alloys at high-pressure. *Geophys. Res. Lett.* **27**, 811-814.

Eleventh Annual V. M. Goldschmidt Conference

May 20-24, 2001
The Homestead
Hot Springs, Virginia, USA

Additional information is on the Conference Web site:

<http://www.lpi.usra.edu/meetings/gold2001/>

Geochemistry Division
American Chemical Society
222nd National Meeting, Chicago IL
 August 26-30, 2001

Electronic Abstract Deadline: April 30, 2001

Abstracts can be submitted electronically after March 1 at:
<http://OAsys.acs.org>

For more information, visit the ACS web site at:
<http://www.acs.org/meetings/chicago2001>

or the Geochemistry Division web site at:
<http://membership.acs.org/G/GEOC/>

Geochemistry Division Symposia:

Program Chair: Peggy O'Day, Arizona State U. (oday@asu.edu)

Contaminant Geochemistry in the Hanford Vadose Zone (Oral symposium #1639) Cosponsored with Division of Nuclear Chemistry & Technology

Organizers: Samuel J. Traina, School of Natural Resources, The Ohio State U., Kottman Hall, 2021 Coffey Road, Columbus, OH 43210, traina.1@osu.edu; Calvin C. Ainsworth, Interfacial Geochemistry, Pacific Northwest National Lab., P.O. Box 999, MSN K3-61, Richland, WA 99352, calvin.ainsworth@pnl.gov

This symposium will highlight field and laboratory studies related to the understanding of metal and radioactive contaminant chemistry in the Hanford vadose zone. Abstracts from recent DOE-sponsored research projects are especially encouraged.

Geochemical and Environmental Applications of Molecular Isotopic Analysis (Oral symposium #1674) Cosponsored with the Organic Geochemistry Division of the Geochemical Society

Organizers: Ken Peters, ExxonMobil Upstream Research Company, P.O. Box 2189, Houston, TX 77252-2189, ken_peters@email.mobil.com; Peggy Ostrom, Dept. of Geological Sciences, Michigan State University, 206 Natural Science Building, East Lansing, MI 48824-1115, ostrom@pilot.msu.edu; Bob Dias, Dept. of Chemistry and Biochemistry, Old Dominion University, Norfolk, VA 23529, rfdias@odu.edu

Abstracts are invited in the following areas related to advances and applications of molecular isotopic analysis:

(1) Petroleum Exploration and Production: Isotopic compositions of individual compounds in crude oils, gases, and associated waters; source-rock paleoenvironment.

(2) Global Biogeochemical Cycling: Paleoclimate; ¹⁴C age dating; marine trophic studies; deep sediment contributions; black carbon in ice; early life.

(3) Ecological Tracers and Environmental Monitoring: Nutrients in watersheds; microbial consortia; wetland processes; contaminant degradation; bioremediation.

Spectroscopic Characterization of Metal Contaminants in Natural Systems (Oral symposium #1316)

Organizer: Martine C. Duff, Westinghouse Savannah River Company, Savannah River Technology Center, Aiken, SC 29808, Phone: 803-725-5276, Martine.Duff@srs.gov

In environmental systems, metal contaminants can be present as dissolved, sorbed, and solid phase species. Spectroscopic analytical methods such as X-ray absorption, luminescence, photoacoustic, nuclear magnetic resonance, infrared, Raman and other techniques have been applied to the characterization of various metals in well-defined synthetic environmental matrices. However, due to the inherent and complex biogeochemical properties of most natural samples, additional challenges lie with the application of microprobe and bulk phase spectroscopic techniques towards the characterization of metals in natural aqueous and geologic environmental samples. Presentations are invited that will explore the application of spectroscopic methods to the characterization of metal contaminants in "real world" samples. Papers that utilize a multimethod approach with wet chemical and spectroscopic techniques or comparisons between natural and model systems are especially welcome.

Surface Reactivity and Catalysis in Geological Systems (Oral symposium #1306) Cosponsored with Division of Colloid and Surface Chemistry

Organizers: Martin Schoonen, Department of Geosciences, SUNY Stony Brook, Stony Brook, NY 11794-2100, mschoonen@notes.cc.sunysb.edu; Daniel R. Strongin, Department of Chemistry, Temple University, 1901 N. 13th St, Philadelphia, PA 19122, dstrongi@nimbus.ocis.temple.edu

The emerging area of geocatalysis plays an important role in a wide variety of fundamental geochemical processes and has implications for basic chemistry related to such diverse areas as contaminant transport and remediation, nanoscience and technology, biomineralization, and astrobiology. This interdisciplinary symposium will focus on recent studies related to mineral surface reactivity and catalysis in geochemistry, Earth materials, soil sciences, and biogeochemistry.

Geochemistry Division Co-sponsored Symposia:

Environmental Management Science Program, sponsored by the Division of Nuclear Chemistry and Technology

Organizers: A. R. Felmy, MS K8-96, Battelle Pacific Northwest Laboratory, Richland, WA 99352, (509) 376-4079, e-mail: ar.felmy@pnl.gov; K. L. Nagy, Dept. of Geological Sciences, U of Colorado, Campus Box 0399, Boulder, CO 80309, (303) 492-6187, fax (303) 492-2606, e-mail: nagyk@spotcolorado.edu

Recent research funded by the Department of Energy's Environmental Management Science Program.

Gordon Research Conference: Inorganic Geochemistry

Formation, modification, and preservation of ore deposits: Tectonic, climatic and surficial factors

19-24 August 2001, Proctor Academy, New Hampshire, USA

Gordon Research Conferences (GRC) are held on a wide variety of subjects, with the goal of generating dialogue among researchers and members of industry through the presentation of cutting-edge advances in an "off-the-record" informal environment. The mineral-deposit community organizes Gordon conferences every four years under the broad title of "Inorganic Geochemistry". This year's conference will highlight research on the generation of some of the world's largest Cu, Au, Ni, Fe, and Mn deposits, particularly processes that influence the modification and preservation of ores and hence their economic viability. This important topic has seen minimal discussion in recent conferences, and we hope that the GRC will provide a venue to review critical applied and fundamental questions related to tectonics, fluid circulation, climate and weathering, bacterial activity, and metal enrichment. Four speakers from the minerals industry will open the conference by highlighting questions related to exploration and development. This will be followed by seven technical sessions (titles of talks listed at www.grc.uri.edu under Inorganic Geochemistry), plus an informal open session on experimental and analytical advances relevant to ore deposits. A final wrap-up discussion will focus on the frontiers and opportunities for research on the broad theme of the conference.

Limited financial assistance will be available for graduate students and young professionals (assistant professors) engaged in research relevant to the theme of the conference. Apply to Jeff Hedenquist (Gordongeochem@aol.com). Preference will be given to those presenting posters. To submit a poster for consideration, send a one-page abstract to Jean Cline (jccline@nevada.edu). Decisions on acceptance of posters and financial assistance will be made in May.

Registration fee (inclusive of room and board):
\$595 (double), \$650 (single).

Attendance at Gordon Research Conferences is limited. For further information and to apply to attend, visit the GRC web site, www.grc.uri.edu or contact GRC, University of Rhode Island, PO Box 984, West Kingston, RI, 02982-0984, USA. Fax 1-401-783-7644.

John Thompson, Teck Corporation, Vancouver, and
Jeff Hedenquist, Ottawa, co-chairs
Jean Cline, University of Nevada – Las Vegas, vice-chair

Industry Perspective:

Eric Seedorff, Speciality Product Systems
James Macdonald, Billiton
Cam Allen, Cominco
Richard Moore, Falconbridge
Neil Phillips, Melbourne

Metal mobility in the natural environment:

Gordon Southam, N Arizona Univ
Jill Banfield, Univ Wisconsin
Charlie Alpers, USGS
Derek Lovley, Univ Massachusetts

Climate, tectonics and metal mobility:

Dick Holland, Harvard Univ
Jerry Dickens, James Cook Univ
Dave Leach, Dwight Bradley, USGS

Metal enrichment - Cu and Au:

Dick Sillitoe, London
Paulo Vasconcelos, Univ Queensland
George Brimhall, UC Berkeley
Phillipe Freysinnet, BRGM

Tectonics and ore deposits:

Dick Tosdal, Univ British Columbia
Rich Goldfarb, USGS
Suzanne Kay, Cornell Univ

Metal enrichment - Ni, Fe and Mn:

Hiroshi Ohmoto, Penn State Univ
Mark Barley, Univ W Australia
Charles Butt, CSIRO
Nigel Brand, Anglo American
Mick Elias, WMC
Nic Beukes, Rand Univ

Paleosurface: Preservation and destruction:

Steve Kesler, Univ Michigan
Bruce Taylor, GSC
Mark Hannington, GCS

Crustal fluid circulation:

Rick Sibson, Univ Otago
Nick Oliver, James Cook Univ
Alison Ord, CSIRO
Martin Appold, Univ Iowa

Experimental and analytical advances: An informal session:

Bob Bodnar, VPI

Research Frontiers:

Ross Large, Univ Tasmania
Murray Hitzman, Colorado School of Mines
Bob Bodnar, Virginia Polytechnic
Larry Cathles, Cornell Univ
Noel White, Brisbane

March 4 to 7, 2002

Bremen, Germany

**GeoProc2002
International Conference**

Schwerpunktprogramm 546 der Deutschen Forschungsgemeinschaft
**Geochemische Prozesse mit Langzeitfolgen im anthropogen beeinflussten
Sickerwasser und Grundwasser**

Priority Program 546 of the Deutsche Forschungsgemeinschaft
**Geochemical processes with long-term effects in anthropogenically affected
seepage and groundwater**

Program and Organisation: Fachbereich 5 – Geowissenschaften, Universität Bremen
Postfach 330 440, D-28 334 Bremen, www.geochemie.uni-bremen.de

Prof. Dr. Horst D. Schulz Phone / Fax: +49 (421) 218 3393 / 4321 Email: hdschulz@uni-bremen.de

Dr. Astrid Hadelier Phone / Fax: +49 (421) 218 3950 / 4321 Email: ahadelier@uni-bremen.de

EU MARIE CURIE TRAINING SITE

for EU member and Associated States Ph.D. students studying

- *Geochemistry* · *Palaeontology*
- *The Earth's Interior*
- *Volcanology & Geological Fluid Dynamics*

ACE Training Site, Department of Earth Sciences
University of Bristol
Queen's Road, Bristol BS8 1RJ, U.K.

Travel and subsistence expenses are supplied

Funded by the **European Commission - Improving Human Research Potential** program.

For more information and application details: <http://mcts.gly.bris.ac.uk>
or contact *Prof. B.J. Wood* b.j.wood@bristol.ac.uk

Application deadlines: 31/3/01, 30/6/01, 30/9/01. Successful applicants will be invited for stays of **3-12 months**.

Meetings Calendar

- May 2-4, 2001: ECROFI-16. European Current Research on Fluid Inclusions**, Porto, Portugal. Abstract deadline: January 5, 2001. Contact: XVI ECROFI, Departamento de Geologia, Faculdade de Ciências, Praça Gomes Teixeira, 4099-002 Porto, Portugal; Phone: +351-22-3401471; Fax: +351-22-2056456; E-mail: ecrofi@fc.up.pt. Web site: <http://www.fc.up.pt/geo/ecrofi/>
- May 7-11, 2001: GEOTROP 01: The Fourth International Conference on Environmental Chemistry and Geochemistry in the Tropics**, Townsville, Queensland, Australia. Contact: Dr. Andrew D. Noble, CSIRO Land and water, PMB, PO Aitkenville, Queensland, Australia; E-mail: Andrew.Noble@tv1.clw.csiro.au.
- May 17-19, 2001: New Developments in Metalliferous Hydrothermal Systems**, Jupiters Hotel, Townsville, Queensland, Australia. Economic Geology Research Unit and the JCU chapter of SEG. Contact: Lucy Chapman, Economic Geology Research Unit, School of Earth Sciences, James Cook University, Townsville QLD 4811, Australia; E-mail: lucy.chapman@jcu.edu.au.
- May 19-25, 2001: Impact Markers in the Stratigraphic Record: 6th workshop of the ESF-IMPACT Programme**. Contact: Francisca C. Martinez-Ruiz, Instituto Andaluz de Ciencias de la Tierra (CSIC-UGR), Fac. Ciencias, Fuentenueva s/n., 18002 Granada (Spain); Fax: 34 958 243384; e-mail: fmruiz@ugr.es. Web site: www.ugr.es/~impact/
- May 19-20, 2001: Molecular Modeling Theory and Applications in the Geosciences**, Geochemical Society and Mineralogical Society of America Short Course, Roanoke, Virginia, USA. Convenors: R. T. Cygan and J. D. Kubicki. Web site: www.sandia.gov/eeselector/GScourse.htm; *Registration form on page 7 of this issue.*
- May 20-24, 2001: Goldschmidt 2001**, Roanoke, VA, USA. Contacts: Mike Hochella (hochella@vt.edu) and Bob Bodnar (bubbles@vt.edu), Department of Geological Sciences, Virginia Tech, Blacksburg, VA 24061-0420. Web site: www.lpi.usra.edu/meetings/gold2001/. *Preregistration and Lodging forms, page 14-15 of previous issue.*
- May 21-25, 2001: 4th International Symposium on Eastern Mediterranean Geology**, Isparta, Turkey. Contact: Prof. Dr. Omer Akinci, S. D. University, Geology Dept., 32260 Isparta, Turkey; Phone: +90246 2370855; Fax: +90 246 2370859; E-mail: oakinci@mmf.sdu.edu.tr.
- May 23-June 3, 2001: Strength From Weakness: Structural Consequences of Weak Interactions in Molecules, Supermolecules, and Crystals**, Erice, Italy. Web site: www.geomin.unibo.it/orgv/erice/strength.htm
- May 27-30, 2001: Geological Association of Canada-Mineralogical Association of Canada Annual Joint Meeting**, St. John's, Newfoundland. <http://www.geosurv.gov.nf.ca/stjohns2001/>
- May 27-June 1, 2001: Sixth Southern Hemisphere Meeting on Minerals Technology**, Rio De Janeiro, Brazil. Contact: Roberto Emery Trindade, Centro de Tecnologia Mineral; Phone: +55 21 560 7222 ext. 201. Web site: www.cetem.gov.br/shmmt.html.
- May 28-31, 2001: 6th International Symposium on Mining in the Arctic** - Mining and Man, KATUAQ, Greenland. Cultural Centre, Nuuk, Greenland, Bureau of Minerals and Petroleum, Government of Greenland, and the International Arctic Mining Advisory Council. Contact: Hans Kristian Olsen, Bureau of Minerals and Petroleum, Government of Greenland, P.O. Box 930, DK-3900 Nuuk, Greenland; Phone: +299 34 68 00; E-mail: bmp@gh.gl. Web site: www.bmp.gl.
- May 29-June 2, 2001: Spring Meeting of the American Geophysical Union**, Boston, MA, USA. Web site: www.agu.org/meetings/
- June 3-6, 2001: Eurock - ISRM Regional Symposium**, Espoo, Finland. Web site: <http://www.hut.fi/events/eurock2001>.
- June 7-12, 2001: Penrose Conference - Longevity and Dynamics of Rhyolitic Magma Systems**, Mammoth, California. Geological Society of America. Contact: Kurt Knesel; E-mail: k.knesel@earth.uq.edu.au. Web site: www.geology.washington.edu/bergantz/penrose-2001.htm.
- June 10-15, 2001: 10th Water-Rock Interaction Symposium**, Tanka Village Congress Centre, Villasimius, Sardinia, Italy. Contact: WRI-10 Scientific Committee Secretariat (Prof. L. Fanfani, secretary general), Department of Earth Sciences, University of Cagliari, Via Trentino 51, I-09127 Cagliari, Italy; Phone: +39 070 6757724; Fax: +39 070 282236; E-mail: wri10@unica.it. Web Site: www.unica.it/wri10/
- June 10-15, 2001: Gordon Conference on the Interior Of The Earth**, Mount Holyoke College, South Hadley, MA, USA
- June 18-22, 2001: Environmental Geochemistry of Ore Deposits and Mining Activities Short Course**, Kjeøy Island (Lofoten), Vestbygd, Norway. SARB Consulting Norge, AS. Contact: Dr. Ingar Walder, P.O. Box 157, N-1322 Høevik, Norway; Phone: +47 67536232; E-mail: sarb4you@aol.com. Web site: www.sarb.net.
- June 19-22, 2001: 17th International Mining Congress & Exhibition of Turkey IMCET 2001**, Ankara, Turkey. Web site: www.mining-eng.org.tr/congress
- June 24-28, 2001: Earth System Processes, Edinburgh, U. K.** Joint conference of the Geological Society of America and the Geological Society of London. Web site: www.geosociety.org/meetings/edinburgh/index.htm
- June 25-29, 2001: 9th Coal Geology Conference**, Prague, Czech Republic. Contact: 9th Coal Geology Conference, Faculty of Science, Charles University, Albertov 6, CZ-128 43 Prague 2, Czech Republic; Fax: +420 2249 21736; E-mail: oplusitl@natur.cuni.cz.
- June 25-29, 2001: 4th International Symposium on Applied Isotope Geochemistry (AIG-4)**, Asilomar Conference Center, Pacific Grove, California, U.S.A. Contact: Tom Bullen, tdbullen@usgs.gov
- July 10-13, 2001: Global Change Open Science Conference "Challenges of a Changing Earth"**. Four central themes: Air Quality, the Global Carbon Cycle, Water Resources and Food, Land and Oceans. Web site: www.sciconf.igbp.kva.se/

continued on page 20

continued from page 19

July 24-27, 2001: International Symposium on Isotopomers (ISI 2001), Yokohama, Japan. Web site: <http://nylab.chemenv.titech.ac.jp/ISI2001/isi2001.html>

July 29-Aug. 2, 2001: International Conference on the Biogeochemistry of Trace Elements, University of Guelph, Guelph, Ontario, Canada. Contact: Dr. Kim Bolton, Department of Land Resource Science, University of Guelph, Guelph, Ontario, Canada, N1G 2W1; Phone: +1 519 824 4120 ext. 2531; E-mail: icobte@lrs.uoguelph.ca. Web: <http://icobte.crle.uoguelph.ca>.

July 29- Aug. 4, 2001: 12th International Clay Conference, Bahía Blanca, Argentina. Contact: Fernando Cravero, Secretary-General 12 ICC, Departamento de Geología, Universidad Nacional del Sur, 8000 Bahía Blanca, Argentina; E-mail: 12icc@criba.edu.ar. Web site: <http://www.12ICC.criba.edu.ar>.

Aug. 19-24, 2001: Gordon Research Conference "Formation, Modification and Preservation of Ore Deposits", focusing on geochemical aspects of tectonic, climatic and surficial processes. Proctor Academy, New Hampshire, U.S.A. Co-chairs, John Thompson, Jean Cline and Jeff Hedenquist. Application information at website: www.grc.uri.edu. Click on 2001 Meetings, "Inorganic Geochemistry" for session and speaker updates.

Aug. 25-31, 2001: 20th European Crystallographic Meeting (ECM-20): Crystallography in Natural Sciences and Technology, Kraków, Poland. The Jagiellonian University. In collaboration with Stanislaw Staszic University of Mining and Metallurgy. Contact: ECM20, Conference Secretariat, Faculty of Chemistry, Jagiellonian University, Ul. Ingardena 3, 30-060 Kraków, Poland. E-mail: ECM2001@chemia.uj.edu.pl Web site: <http://www.ch.uj.edu.pl/ECM2001.htm>

Aug. 26-29, 2001: 6th Biennial SGA Meeting -- Mineral Deposits at the Beginning of the 21st Century, Krakow, Poland. Contact: 6th Biennial SGA Meeting, Dr. Wojciech Mayer, University of Mining and Metallurgy, Faculty of Geology, Geophysics & Environmental Protection, av. Mickiewicza 30, 30-059 Kraków, Poland; Phone: +48-12-6172385; Fax: +48-12-6332936, E-mail: wmayer@geol.agh.edu.pl Web site: <http://galaxy.uci.agh.edu.pl/~sga/>

Aug. 27-29, 2001: 6th Biennial Meeting of the Society for Geology applied to Mineral Deposits, Krakau, Poland. Contact: Dr. W. Mayer, Faculty of Geology, Geophysics and Environmental Protection, av. Mickiewicza 30, 30-059 Krakow, Poland; Fax: +48-12-633-2936; E-mail: wmayer@geol.agh.edu.pl. Web site: <http://www.galaxy.uci.agh.edu.pl/sga>.

Aug. 29-Sept. 3, 2001: Submarine craters and Ejecta-Crater Correlation. Workshop and excursion within the European Science Foundation Programme. With a special session on icy impacts and icy targets. University center UNIS, Svalbard, Norway. Web site: <http://www.geologi.uio.no/avdG/esf-svalbard2001>

Aug. 31-Sept. 12, 2001: Field Excursion to the Skaergaard Intrusion, Skaergaard area, Kangerdlugssuaq, East Greenland. IGCP Project 427, SGA. Contact: Dr. Jens C. Andersen, Camborne School of Mines, University of Exeter, Redruth, Cornwall, TR15 3SE, UK; Phone: +44 1209 714866; E-Mail: andersen@csm.ex.ac.uk. Web site: <http://www.ex.ac.uk/CSM/news/confs.htm>

Sept. 3-4, 2001: International Conference on Cathodoluminescence and related techniques in Geosciences and Geomaterials, Freiberg, Germany. Organized by: Society for Luminescence Microscopy and Spectroscopy (SLMS), German Mineralogical Society. First circular can be ordered from: Jens Götze, Vice president of SLMS, Department of Mineralogy, Freiberg University of Mining and Technology, Brennhausgasse 14, 09596 Freiberg, Germany; E-mail: goetze@mineral.tu-freiberg.de. Web site: <http://sonne.hrz.tu-freiberg.de/>.

Sept. 3-7, 2001: Écorad 2001 -International congress on the radioecology-ecotoxicology of continental and estuarine environments, Palais des congrès, Aix-en-Provence, France. Abstract deadline: October 2000. Contact: ECORAD 2001 - IPSN-DPRE – Bât. 02, Rue Auguste Lemaire B.P. n°6 / 92265, Fontenay-aux-Roses cedex, France; Phone: +33 1 46 54 79 06; Fax: +33 1 46 54 72 90; E-mail: ecorad.2001@ipsn.fr <http://www.ipsn.fr/ecorad2001>. Web sites: <http://www.ipsn-dpre.com/ecorad2001> and <http://www.ipsn-dpre.com/ecorad2001/>

Sept. 6-8, 2001: CL2001 - Cathodoluminescence in Geosciences. New insights from CL in combination with other techniques, Freiberg, Germany. Organized by Freiberg University of Mining and Technology and Ruhr-University Bochum. Contact: CL 2001 Secretariat, Freiberg University of Mining and Technology, Department of Mineralogy, Brennhausgasse 14, 09596 Freiberg/Sachsen, Germany; Phone: +49 3731 392 628 or +49 3731 393 129; E-mail: goetze@mineral.tu-freiberg.de. Web site: <http://www.mineral.tu-freiberg.de>.

Sept. 10-14, 2001: 20th International Meeting on Organic Geochemistry (IMOG 2001), Nancy, France. Abstract deadline: December 1, 2000. Contact: E-mail: imog2001@g2r.uhp-nancy.fr. Web site: <http://www.imog.uhp-nancy.fr>

Sept. 15-20, 2001: The Deep Earth: Theory, Experiment and Observation: Mantle Processes, Espinho (near Porto), Portugal. Contact: J.A.M. Paulssen, Earth Sciences, University Utrecht, Budapestlaan 4, 3584 CD UTRECHT, The Netherlands; Phone: +31 30 2535089; fax: +31 30 2533486; E-mail: paulssen@geo.uu.nl. Web site: <http://www.esf.org/euresco/01/lc01125a.htm>

Sept. 17-21, 2001: 7th International Conference on Paleoceanography (ICP7), Sapporo, Japan. Abstract Deadline: March 10, 2001. Co-Conveners: Hisatake Okada (Dept. of Earth and Planetary Sciences, Graduate School of Science, Hokkaido University, Sapporo, 060-0810, Japan. Phone: 81-11-706-3537. Fax: 81-11-746-0394. E-mail: oka@cosmos.sci.hokudai.ac.jp), Itaru Koizumi, and Tadamichi Oba

Sept. 23-25, 2001: 18th Annual Meeting Society for Organic Petrology (TSOP), Westchase Hilton and Towers, Houston, TX, USA. Contact: Dr. Coleman Robison, Texaco E&P Technology Divison, 3901 Briarpark Dr., Houston, TX 77042; Phone: +1 713 432 6828; E-Mail: robiscr@texaco.com. Web site: <http://www.tsop.org>.

Oct. 21-24, 2001: Third South American Symposium on Isotope Geology, Gran Hotel Pucón, Pucón, Chile. Organized by the Servicio Nacional de Geología y Minería de Chile (SERNAGEOMIN), Dept. de Geología, Universidad de Chile, and Sociedad Geológica de Chile. Contact: Eugenia Fonseca, Laboratorio Sernageomin, Til-Til 1993 Ñuñoa, Santiago, Chile; Phone: + 56 2 2385292; E-Mail: ssagi@sernageomin.cl. Web site: <http://www.sernageomin.cl/ssagi/>

Oct. 21-25, 2001: 8th Annual Meeting of the International Society for Reef Studies, Eilat, Israel. Contact: Christian Dullo, Geomar, 24128 Kiel; E-mail: reefs@newsup-univ.mrs.fr.

Nov. 5-8, 2001: Geological Society of America Annual Meeting, Boston, MA USA. Contact: GSA Meetings, Box 9140, Boulder, Colo. 80301-9140. Tel: +1-303-447-2020, ext. 164; Fax: +1-303-447-1133; WWW: <http://www.geosociety.org/meetings/index.htm>

Nov. 7-9, 2001: 3rd Asia Symposium on Environmental Geochemistry, Guangzhou, China. Contact: Dr. Ron T. Watkins, Secretary, SEGH, Asia/Pacific Branch, Environmental Inorganic Geochemistry Group, Curtin University of Technology, GPO Box U1987, Perth 6845, Australia; E-mail: iwatkins@info.curtin.edu.au. Web site: <http://www.gigac.cn/apseg.htm>.

Dec. 10-14, 2001: Fall Meeting of the American Geophysical Union, San Francisco, California, USA. Web site: <http://www.agu.org>

Feb. 11-15, 2002: AGU Ocean Sciences Meeting, Honolulu, Hawaii, USA. Web site: <http://www.agu.org>.

Mar. 4-7, 2002: GeoProc 2002: Geochemical processes with long-term effects in anthropogenically affected seepages and groundwaters, Bremen, Germany. Contact: Dr. Astrid Haderler, Universität Bremen, FB 5 - Geowissenschaften, Geochemie & Hydrogeologie, Postfach 330 440, D-28334 Bremen; ++49 (0)421 218 3950; ++49 (0)421 218 4321; ahaderler@uni-bremen.de

March 11-13, 2002: Geo 2002: The 5th Middle East Geosciences Exhibition and Conference, Bahrain. Contact: Overseas Exhibition Services Ltd., 11 Manchester Square, London W1M 5AB, UK; Phone: +44 207 8622000; Fax: +44-202-862-2078. E-mail: pmckean@montnet.com.

March 20-27, 2002: Annual Meeting National Earth Science Teachers Association, San Diego, CA, USA. Contact: NESTA Meetings, 2000 Florida Avenue, N.W., Washington, D.C. 20009, USA; Phone: +1 202 462 6910; Fax: +1 202 328 0566; E-mail: fireton@kosmos.agu.org

May 8, 2002: 100th Anniversary of the eruption of Mt. Pelee. International Association of Volcanology and Chemistry of the Earth's Interior (IAVCEI) workshop, Martinique. Web site: <http://www.iavcei.org>.

July 22-27, 2002: The Earth System and Metallogensis - 11th Quadrennial IAGOD Symposium and GEOCONGRESS 2002, Windhoek, Namibia. Main theme: Sedimentary and magmatic responses to compressional and extensional tectonics and the associated ore-forming processes. Hosted by: The Geological Society of Namibia, the Geological Society of South Africa, The Geological Society. Contact: IAGOD/GEOCONGRESS 2002, P.O. Box 44283, Linden 2104, South Africa; Fax: +27 11 791 1264; E-mail: gssa@pop.onwe.co.za. Web site: <http://www.gssa.org.za>.

Aug. 17-23, 2002: 12th V. M. Goldschmidt Conference, Davos, Switzerland.

Sept. 9-13, 2002: Mineralogy for the new millenium (IMA 2002), 18th General Meeting of the International Mineralogical Association, Edinburgh, United Kingdom. Contact: Mr K. Murphy, Executive Secretary, Mineralogical Society of Great Britain and Ireland, 41 Queen's Gate, London SW7 5HR, United Kingdom: Phone: +44 171 584 7516; E-mail: IMA@minersoc.demon.co.uk.

Sept. 16-20, 2002: Uranium Mining and Hydrogeology III - International Mine Water Association. Symposium - Mine Water and The Environment, Freiberg, Germany. Contact: Prof. Dr. B. Merkel, Dr. Christian Wolkersdorfer, Lehrstuhl für Hydrogeologie; Gustav-Zeuner-Str. 12; D-09596 Freiberg/Sachsen, Germany; Phone: +49. 3731 39 3309; Fax: +49 3731 39 2720; E-mail: UMH@IMWA.de. Web site: <http://www.IMWA.de>.

Oct. 24-26, 2002: Synchrotrons, Low Temperature Geochemistry, and Environmental Science, Estes Park, Colorado. Geochemical Society and Mineralogical Society of America Short Course (details in next issue of GN)

October 27-30, 2002: Geological Society of America Annual Meeting, Denver, Colorado, USA. Contact: GSA Meetings, Box 9140, Boulder, Colo. 80301-9140. Tel: +1-303-447-2020, ext. 164; Fax: +1-303-447-1133; WWW: <http://www.geosociety.org/meetings/index.htm>

Sept. 7-11, 2003: 6th International Symposium on Environmental Geochemistry (ISEG), Edinburgh, UK. Contact: Dr. John G. Farmer, Department of Chemistry, University of Edinburgh, West Mains Road, Edinburgh EH9 3JJ, UK; E-mail: J.G.Farmer@ed.ac.uk.

The Deep Earth: Theory, Experiment and Observation

Mantle Processes

Espinho (near Porto), Portugal, 15 - 20 September 2001

Supported by the European Commission, Research DG, as a EuroConference under TMR contract ERBFMMACT n° 98-0381

Chairwomen: **Hanneke Paulssen (Utrecht, NL) & Janne Blichert-Toft (Lyon, F)**

Vice-Chairman: **Mike Kendall (Leeds, UK)**

Scientific programme available at: <http://www.esf.org/euresco/01/lc01125a.htm>

Deadline for applications: 27 April 2001

For information & application forms, contact the Head of the EURESCO Unit:
Dr. J. Hendekovic, European Science Foundation, 1 quai Lezay-Marnésia, 67080 Strasbourg Cedex, France
Tel.+33 388 76 71 35 Fax.+33 388 36 69 87 E-mail: euresco@esf.org
On-line information and application on WWW at: <http://www.esf.org/euresco>



THE GEOCHEMICAL SOCIETY

Special Publications Series Order Form

(last revised 9/30/2000)

Volume	Title	Price (US\$)	Quantity	Total by Volume
1	Magmatic Processes: Physicochemical Principles. A volume in honor of Hatten S. Yoder, Jr., edited by B.O. Mysen (1987) (ISBN 0-941809-00-5)	25.00		
2	Fluid-Mineral Interactions: A Tribute to H.P. Eugster, edited by R.J. Spencer and I.-M. Chou (1990) (ISBN 0-941809-01-3)	25.00		
3	Stable Isotope Geochemistry: A Tribute to Samuel Epstein, edited by H.P. Taylor <i>et al.</i> (1991) (ISBN 0-941809-02-1)	25.00		
4	Victor Moritz Goldschmidt: Father of Modern Geochemistry, by Brian Mason (1992) (ISBN 0-941809-03-X)	20.00		
5	Mineral Spectroscopy: A Tribute to Roger G. Burns, edited by M.D. Dyar <i>et al.</i> (1996) (ISBN 0-941809-04-8)	40.00*/60.00		
6	Mantle Petrology: Field Observations and High-Pressure Experimentation, A Tribute to Francis R. (Joe) Boyd, edited by Y. Fei, C.M. Bertka and B.O. Mysen (1999) (ISBN 0-941809-05-6)	60.00*/90.00		
SPECIAL OFFER	For Members Only!!! The COMPLETE SIX VOLUME SET (a \$195.00 value) Offer expires June 30, 2001	120.00*		

* members only discount price

Grand Total \$ _____

Name: _____
(First) (M) (I) (Last)

I am: _____
A member of the Geochemical Society
Not a member of the Geochemical Society

Affiliation/Address/Contact Information

Department _____
Institution _____
Street Address _____
City, State, Postal Code _____
Country _____
Phone _____
Fax _____
Email _____

Payment/Payment Method

Payment in US Dollars only. Payment may be made by check, money order, or by credit card authorization. Please do not send cash. Sorry, we cannot invoice, accept purchase orders, or process bank transfers. All payments must be made to The Geochemical Society. *Prices include Shipping.* Please send payment to the address at the bottom left.

Payment Type:

Check _____ Money Order _____
MasterCard _____ Visa _____ American Express _____
Card Number _____
Expiration Date ____/____

Send Completed form to:
The Geochemical Society
Department of Earth & Planetary Sciences
Washington University
One Brookings Drive
St. Louis, MO 63130-4899, USA



GS Business Office Contact Information
Phone: 314-935-4131
FAX: 314-935-4121
Email: gsoffice@gs.wustl.edu
Website: gs.wustl.edu

THE GEOCHEMICAL SOCIETY

2001 Application/Renewal Form

(last revised 9/30/2000)

Name: _____
 (First) (MI) (Last)

Is this a Renewal
 New Membership

Affiliation/Address/Contact Information

Department _____
 Institution _____
 Street Address _____
 City, State, Postal Code _____
 Country _____
 Phone _____
 Fax _____
 Email _____

Payment in US Dollars only. Payment may be made by check, money order, or by credit card authorization. Please do not send cash. Sorry, we cannot invoice, accept purchase orders, or process bank transfers.

Payment Type:

Check Money Order
 MasterCard Visa American Express

Card Number _____
 Expiration Date ____/____

Payment/Payment Method

Membership Category

All members receive a subscription to *The Geochemical News* (The Geochemical Society's Quarterly Newsletter). If you begin your subscription late you must request back issues of *The Geochemical News*. Subscription to *Geochimica et Cosmochimica Acta (GCA)* is by calendar year (e.g. January 2001 through December 2001). If you begin your subscription after the beginning of the calendar year, you will be sent back issues for those that were missed.

- 2001 Professional Membership only (\$25.00 US)
- 2001 Professional Membership with *GCA* Subscription (\$147.00 US)
- 2001 Student Membership* only (\$5.00 US)
- 2001 Student Membership* with *GCA* Subscription (\$50.00 US)

Yes, I wish to be Affiliated with the Organic Geochemistry Division (OGD) at no extra charge

*Student Certification

For student application/renewals, a faculty member in the student's department must either sign below or must write a letter of certification to be included with this form.

"I hereby certify that the individual herein applying for GS Membership is a student in good standing in my department."

Name _____
 Title _____
(please print)
 Signature _____
 Date _____

Interest Areas – Check as many as apply

- (1) Analytical geochemistry
- (2) Aqueous geochemistry
- (3) Atmospheric geochemistry
- (4) Cosmochemistry and meteorites
- (5) Crustal mineralogy, petrology, trace elements
- (6) Environmental & toxicologic geochemistry
- (7) Experimental geochemistry
- (8) Geochemical education
- (9) Low-temperature & interface geochemistry
- (10) Mantle mineralogy, petrology, trace elements
- (11) Marine geochemistry & chemical oceanography
- (12) Ore deposit and hydrothermal geochemistry
- (13) Organic geochemistry
- (14) Planetary geochemistry
- (15) Radiogenic and stable isotope geochemistry

Additional Comments: _____

Send Completed form to:
The Geochemical Society
 Department of Earth & Planetary Sciences
 Washington University
 One Brookings Drive
 St. Louis, MO 63130-4899, USA



GS Business Office Contact Information
 Phone: 314-935-4131
 FAX: 314-935-4121
 Email: gsoffice@gs.wustl.edu
 Website: gs.wustl.edu

The Geochemist's Workbench®

Graphical solutions to your tough problems — in minutes!

New!!! Version 3.1 for Windows 95/98 and NT

H₂O • Ag⁺ • Am³⁺ • As(OH)₄⁻ • Au⁺ • B(OH)₃ • Ba²⁺ • Br⁻ • Ca²⁺ • HCO₃⁻ • Cs⁺ • Cl⁻ • Co²⁺ • Cr³⁺ • Cu⁺ • Eu³⁺

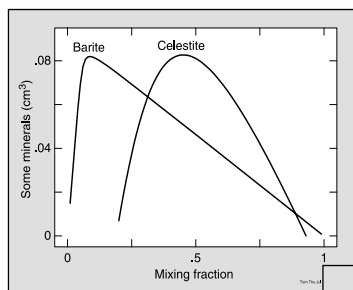

Mineral scales formed when formation fluid from a North Sea oil field mixes at reservoir temperature with seawater.

Species distribution of uranyl vs. Ph, in the presence of phosphate.

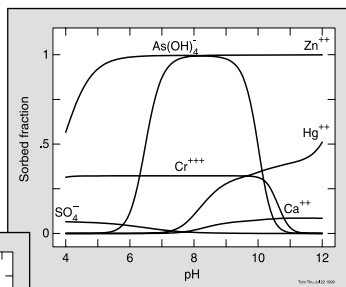
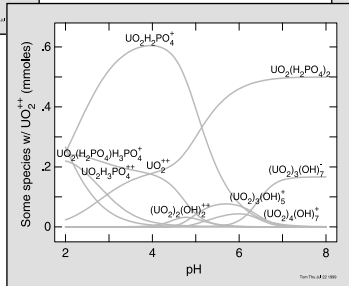

Predict sorption vs. pH of metals onto HFO.

Applications of *GWB* include —

- Environmental protection and remediation
- Petroleum and minerals industries
- Nuclear waste repository design
- Acid mine drainage
- Ore leachate design
- General geochemistry
- Classroom education

Your personal toolkit for—

- Reaction paths
- Kinetic rate laws
- Isotope fractionation
- Sorption and surface complexation
- Brine chemistry, "Pitzer equations"
- Temperature-activity diagrams
- Calculating species distribution, speciation diagrams
- Instant reaction balancing, calculation of equilibrium constants and equilibrium equations, temperatures . . .
- Eh-pH, pe-pH, and activity-activity diagrams — in seconds!
- Redox kinetics and catalysis
- Enzymes and biotransformation
- Ion exchange, Langmuir isotherms, K_d sorption and more

Plus —

- Easy-to-use interface designed by geochemists for geochemists!
- Perfect for education
- Call for training!
- Over 200 software solutions at <http://www.rockware.com>

Price —

\$2,900.00 (\$1,600.00 academic)

RockWare, Inc. • 2221 East Street, Suite 101 • Golden, Colorado 80401

800.775.6745, 303.278.3534 • fax: 303.278.4099 • e-mail: sales@rockware.com

Over 200 Software Solutions at <http://www.rockware.com>

The Geochemist's Workbench® is a registered trademark of the University of Illinois.

THE GEOCHEMICAL NEWS
c/o Neil C. Sturchio, Editor
Earth & Environmental Sciences
University of Illinois at Chicago
845 West Taylor St. (MC-186)
Chicago, IL 60607-7059 U.S.A.



NON-PROFIT
U.S. POSTAGE PAID
FOX VALLEY, IL
PERMIT No. 128